

The AFM-16AF Annunciator Fixed Module

*for the Sensiscan 2000
Fire Alarm Control Panels*

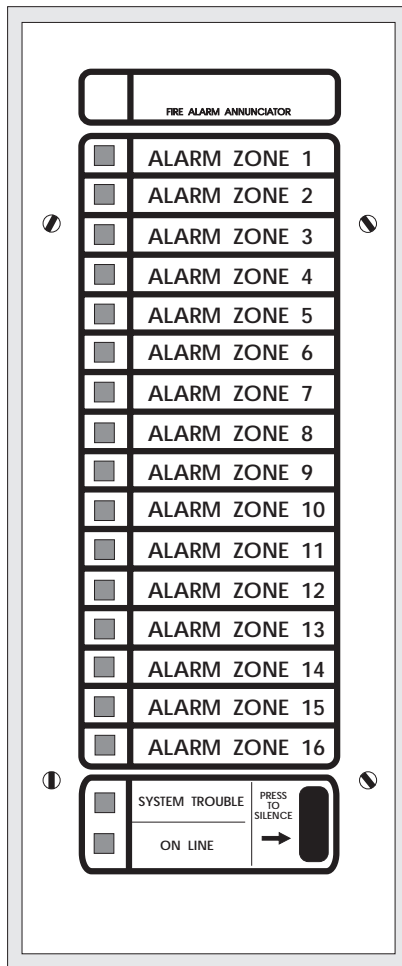

Installation Precautions

Adherence to the following will aid in problem-free installation with long-term reliability:

WARNING - Several different sources of power can be connected to the fire alarm control panel. Disconnect all sources of power before servicing. Control unit and associated equipment may be damaged by removing and/or inserting cards, modules, or interconnecting cables while the unit is energized. Do not attempt to install, service, or operate this unit until this manual is read and understood.

CAUTION - *System Reacceptance Test after Software Changes*: To ensure proper system operation, this product must be tested in accordance with NFPA 72-1993 Chapter 7 after any programming operation or change in site-specific software. Reacceptance testing is required after any change, addition or deletion of system components, or after any modification, repair or adjustment to system hardware or wiring.

All components, circuits, system operations, or software functions known to be affected by a change must be 100% tested. In addition, to ensure that other operations are not inadvertently affected, at least 10% of initiating devices that are not directly affected by the change, up to a maximum of 50 devices, must be tested and proper system operation verified.

This system meets NFPA requirements for operation at 0-49° C/32-120° F and at a relative humidity of 85% RH (non-condensing) at 30° C/86° F. However, the useful life of the system's standby batteries and the electronic components may be adversely affected by extreme temperature ranges and humidity. Therefore, it is recommended that this system and its peripherals be installed in an environment with a nominal room temperature of 15-27° C/60-80° F.

Verify that wire sizes are adequate for all initiating and indicating device loops. Most devices cannot tolerate more than a 10% I.R. drop from the specified device voltage.

Like all solid state electronic devices, this system may operate erratically or can be damaged when subjected to lightning induced transients. Although no system is completely immune from lightning transients and interferences, proper grounding will reduce susceptibility. *Overhead or outside aerial wiring is not recommended, due to an increased susceptibility to nearby lightning strikes.* Consult with the Technical Services Department if any problems are anticipated or encountered.

Disconnect AC power and batteries prior to removing or inserting circuit boards. Failure to do so can damage circuits.

Remove all electronic assemblies prior to any drilling, filing, reaming, or punching of the enclosure. When possible, make all cable entries from the sides or rear. Before making modifications, verify that they will not interfere with battery, transformer, and printed circuit board location.

Do not tighten screw terminals more than 9 in-lbs. Over tightening may damage threads, resulting in reduced terminal contact pressure and difficulty with screw terminal removal.

This system contains static-sensitive components. Always ground yourself with a proper wrist strap before handling any circuits so that static charges are removed from the body. Use static suppressive packaging to protect electronic assemblies removed from the unit.

Follow the instructions in the installation, operating, and programming manuals. These instructions must be followed to avoid damage to the control panel and associated equipment. FACP operation and reliability depend upon proper installation.

Fire Alarm System Limitations

While installing a fire alarm system may make lower insurance rates possible, it is not a substitute for fire insurance!

An automatic fire alarm system - typically made up of smoke detectors, heat detectors, manual pull stations, audible warning devices, and a fire alarm control with remote notification capability can provide early warning of a developing fire. Such a system, however, does not assure protection against property damage or loss of life resulting from a fire.

Any fire alarm system may fail for a variety of reasons:

Smoke detectors may not sense fire where smoke cannot reach the detectors such as in chimneys, in walls, or roofs, or on the other side of closed doors. Smoke detectors also may not sense a fire on another level or floor of a building. A second floor detector, for example, may not sense a first floor or basement fire. Furthermore, all types of smoke detectors - both ionization and photoelectric types, have sensing limitations. No type of smoke detector can sense every kind of fire caused by carelessness and safety hazards like smoking in bed, violent explosions, escaping gas, improper storage of flammable materials, overloaded electrical circuits, children playing with matches, or arson.

IMPORTANT! *Smoke detectors must be installed in the same room as the control panel and in rooms used by the system for the connection of alarm transmission wiring, communications, signaling, and/or power.* If detectors are not so located, a developing fire may damage the alarm system, crippling its ability to report a fire.

Audible warning devices such as bells may not alert people if these devices are located on the other side of closed or partly open doors or are located on another floor of a building.

A fire alarm system will not operate without any electrical power. If AC power fails, the system will operate from standby batteries only for a specified time.

Rate-of-Rise heat detectors may be subject to reduced sensitivity over time. For this reason, the rate-of-rise feature of each detector should be tested at least once per year by a qualified fire protection specialist.

Equipment used in the system may not be technically compatible with the control. It is essential to use only equipment listed for service with your control panel.

Telephone lines needed to transmit alarm signals from a premise to a central monitoring station may be out of service or temporarily disabled.

The most common cause of fire alarm malfunctions, however, is inadequate maintenance. All devices and system wiring should be tested and maintained by professional fire alarm installers following written procedures supplied with each device. System inspection and testing should be scheduled monthly or as required by National and/or local fire codes. Adequate written records of all inspections should be kept.

Contents

Section One:	The AFM-16AF Module	4
	Wiring Specifications	5
	Multiple Annunciators	6
Section Two:	Installation	7
	Installation Summary	7
	Slide-in Labels	8
	Jumper Options	10
	Field Connections	11
	EIA-485 Loop	12
	Main Power Supply Connections	13
Section Three:	Operation	14

Section One:

The AFM-16A Module

The AFM-16AF Annunciator Fixed Module provides the control panel with discrete display and control points. The annunciator turns its LEDs ON and OFF as commanded by the system's CPU. In addition, it reports selected switch activations to the CPU for action.

Limits

The AFM-16AF is intended for use in systems that require 16 annunciation points or less. Each annunciator's address is internally fixed at "1."

Capabilities

The AFM-16AF can annunciate the following:

CPU Points (System Alarm, System Trouble, Activation of Notification Circuits 1 & 2, Relay signaling and Relay)
IZ-4F and IZ-8F Initiating Device Circuits (alarm)
IC-4F and Notification Appliance Circuits (circuit activation)
CR-4F and Control Relays (circuit activation)
TC-2F and TC-4F circuits (circuit activation)

The AFM-16AF is fully compatible with the Sensiscan 2000.

Electrical Ratings

Input Voltage: 24 volts DC (must be power-limited).

Current Draw from 24 volt DC:

Standby current 25mA, Alarm current 65mA

Current draw from secondary power source (batteries): 30mA

Data Communications Port: EIA-485 operating at 20.833 Kbaud (must be power-limited).

Wiring

Communication between the control panel and the AFM is accomplished over a two-wire power-limited EIA-485 serial interface (formerly referred to as RS-485). This communication, to include the wiring, is supervised by the control panel's CPU. Loss of communication results in "System Trouble" and "Module Failure" indications at the CPU. Power for the AFM is provided via a separate power loop from the control panel which is inherently supervised (loss of power also results in a communication failure at the control panel) and must be power-limited. No End-Of-Line Resistor needs to be installed because the EIA-485 circuit is internally terminated on the annunciator.

**Figure 1-1:
Wiring specifications**

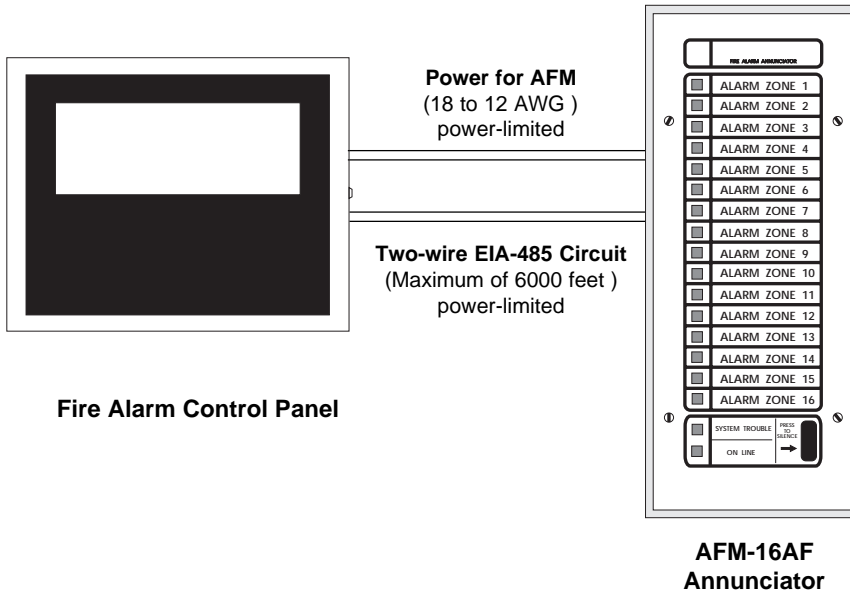

Wiring Specifications

The EIA-485 circuit cannot be T-Tapped; it must be wired in a continuous fashion from the control panel to the AFM. The maximum wiring distance between the panel and annunciator is 4000 feet. The wiring size should be a 18 AWG to 14 AWG twisted-pair cable having a Characteristic Impedance of approximately 120 ohms. Limit the total wire resistance to 100 ohms on the EIA-485 circuit, and to 10 ohms on the power run to the annunciator. Do not run cable adjacent to, or in the same conduit as, 120 volts AC service, noisy electrical circuits that are powering mechanical bells or horns, audio circuits above 25 volts_{RMS}, motor control circuits, or SCR power circuits. Twisted-shielded wiring should be used for EIA-485 circuits that are not contained entirely in conduit.

Functions

The fire alarm control panel automatically assigns annunciator points to the modules directly to the right of the CPU and outward. Therefore, when installing the system modules, Initiating Zone Modules (IZ-4F or IZ-8F) should be installed in ribbon cable positions immediately next to the CPU (and outward) to permit full annunciation of initiating circuits.

Multiple Annunciators

Multiple AFM-16AFs may be used within power supply limits. The final AFM-16AF on the EIA-485 circuit must be configured for receive/transmit while all other AFM-16AFs on the EIA circuit must be configured for receive-only. See Section 2 for terminal designations and jumper locations.

**Figure 1-2:
Multiple AFM-16AFs**

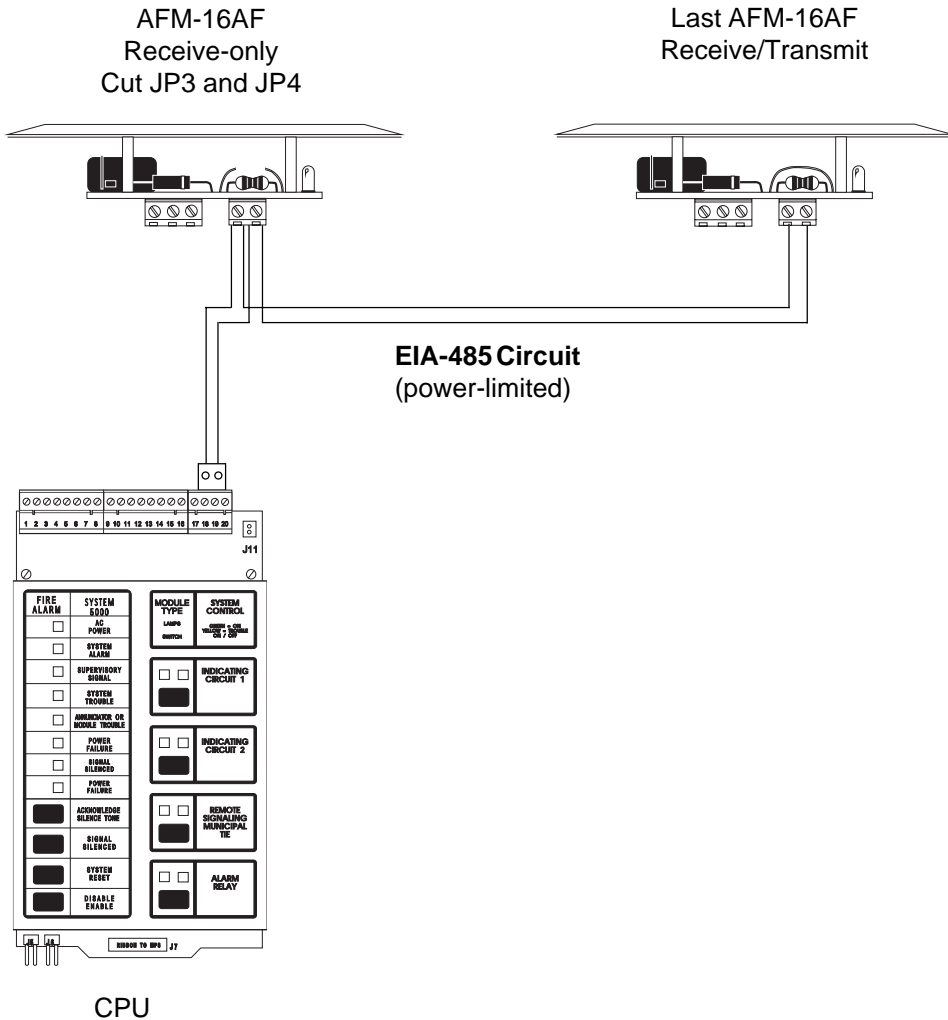

Section Two: Installation

Installation Summary

- ❑ Run the EIA-485 and power circuits out to the location of the annunciator.
- ❑ The AFM-16AF can be mounted to four single-gang boxes ganged together. Select an appropriate knockout on the backbox assembly and mount the backbox.
- ❑ Wire the backbox to a solid ground, such as a properly grounded metallic cold water pipe.
- ❑ Draw all annunciator and power wiring into the enclosure. Do not terminate the shield (if employed) to the backbox .
- ❑ Insert the custom display labels into the annunciator.
- ❑ As appropriate, cut jumper options on the annunciator. (See Figure 2-3)
- ❑ Connect power-limited EIA-485 circuit and power-limited power wiring to the Annunciator Terminal Blocks as illustrated in Figure 2-4.
- ❑ Place the annunciator/dress plate assembly into the backbox and secure with four screws.
- ❑ Connect the EIA-485 circuit to the CPU as illustrated in Figure 2-4.
- ❑ Connect the power loop for the annunciator to the Main Power Supply as illustrated in Figure 2-6.
- ❑ Installation of the AFM Annunciator is complete. Program the AFM into the respective CPU and fully test the system.

Slide-In Labels

Slide-in labels are contained in the center of this manual. Carefully cut out the labels and insert them into the AFM-16AF by slipping them into the label slots on the back side of the annunciator face plate.

Note: To ensure the best fit, cut directly along the dotted line surrounding each label.

Effective Window Size

The size of the visible portion the label window is $5/16$ " high by $2\ 3/16$ " across. Using a pitch of 10 characters per inch at six lines per inch, up to three lines of 10 characters each may be typed within this window space. If information is to be typed onto these labels, make a reproduction on a copy machine to use as a practice copy.

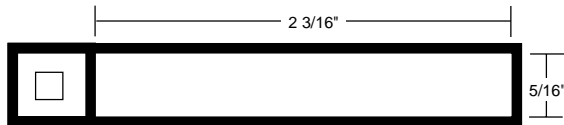

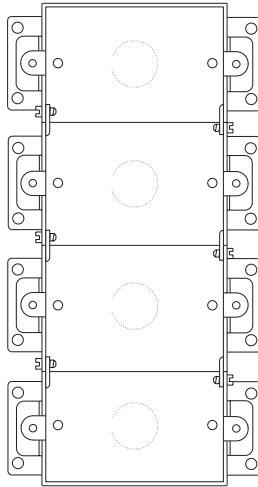

Four single-gang electrical boxes connected together.

Figure 2-1: Mounting the Backbox

Select a knockout on the backbox. Mount the backbox and draw all annunciator, and power wiring into the enclosure. Connect the backbox to a solid ground such as a metallic cold water pipe.

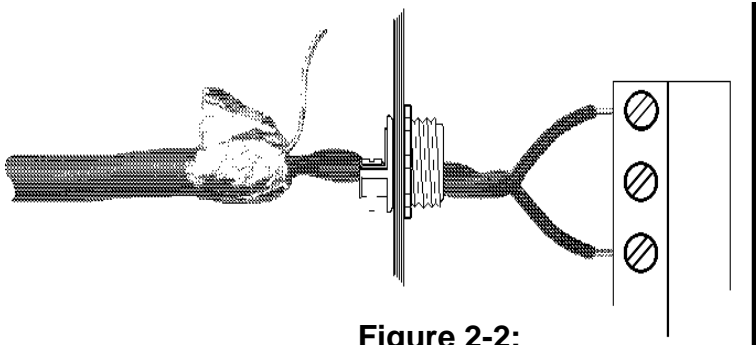
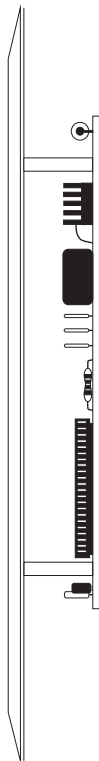

Figure 2-2: Terminating the Shield

The EIA-485 circuit should be wired using a twisted-pair cable having a Characteristic Impedance of approximately 120 ohms. Do not run cable adjacent to, or in the same conduit as, 120-volt AC service, noisy electrical circuits that are powering mechanical bells or horns, audio circuits above 25 volts_{RMS}, motor control circuits, or SCR power circuits. Twisted-shielded wiring should be used for EIA-485 circuits that are not contained entirely in conduit. Do not allow the shield to enter or touch the annunciator enclosure, as illustrated above. The shield should only be terminated at the fire alarm control panel. Wire-nut multiple shields together outside of the cabinet



AFM-16AF
Side View

Jumper JP1 (brown)

Cut this jumper to disable the local piezo from sounding during alarm, trouble, or supervisory activity within the system.

Jumper JP2 (red)

Cut this jumper to display the status of the eight CPU functions in the first eight points on the annunciator.

Jumper JP3 (orange)

Cut this jumper to configure the AFM-16AF for receive-only.

**Figure 2-3:
Annunciator Jumper Options**

Jumper JP4 (yellow)

Cut this jumper if the AFM-16AF is NOT the last device connected to the EIA-485 circuit.

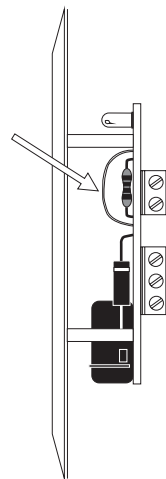

AFM-16AF
Top View

Figure 2-4: Field Connections

Connect the annunciator and power wiring to the terminal blocks on the back of the AFM-16AF as illustrated below.

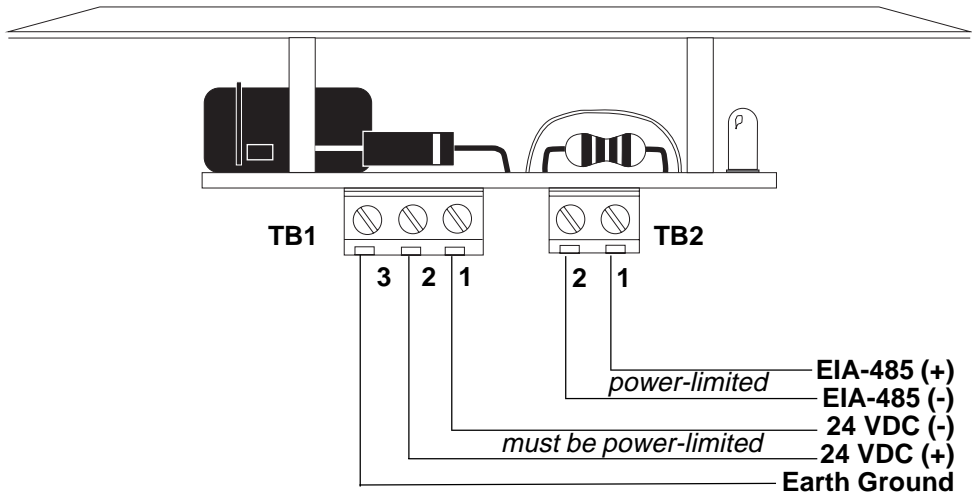

Caution!

Failure to observe proper polarity on these connections may result in damage to the annunciator.

Installation Requirements

The EIA-485 circuit that drives the AFM must be connected to the CPU as illustrated below. Connect the EIA-485 (+) and (-) lines to the CPU terminals.

**Figure 2-5:
Connecting the EIA-485 Loop**

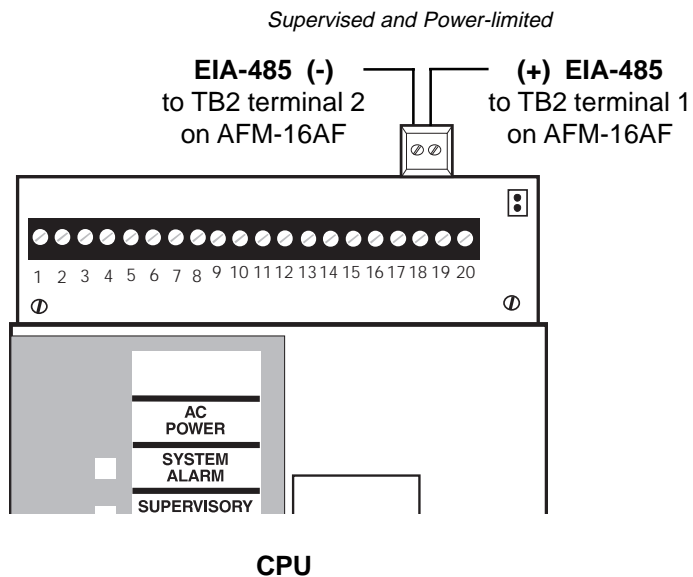

Main Power Supply Connections

The AFM-16AF annunciator can be powered by an MPS-24A or an MPS-24B. This power run to the annunciator need not contain a Power Supervision Relay since loss of power is inherently supervised through communication loss.

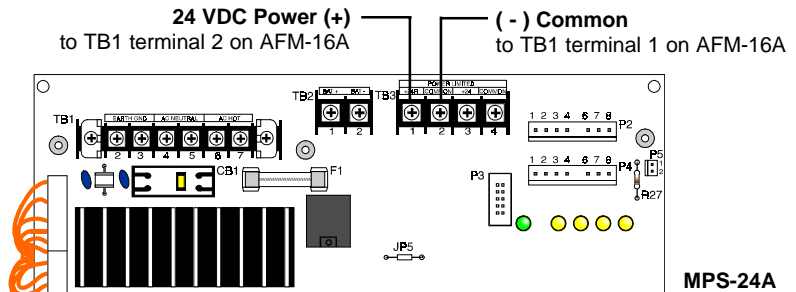

Figure 2-6A:

MPS-24A Main Power Supply :

Connect the power run for the AFM to MPS-24A TB3 Terminals 1 (+) and 2 (-) (1 amp max) or TB3 Terminals 3 (+) and 4 (-) (3 amps max). The total amount of current drawn from these terminals cannot exceed the above ratings in standby or in alarm.

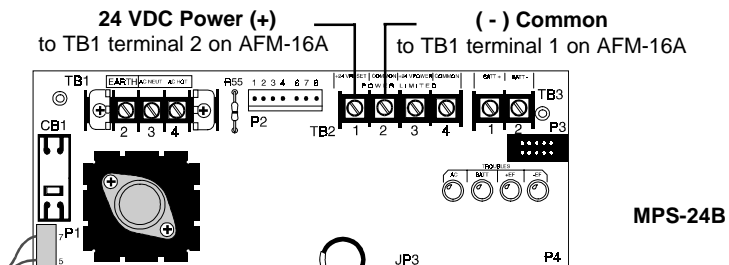
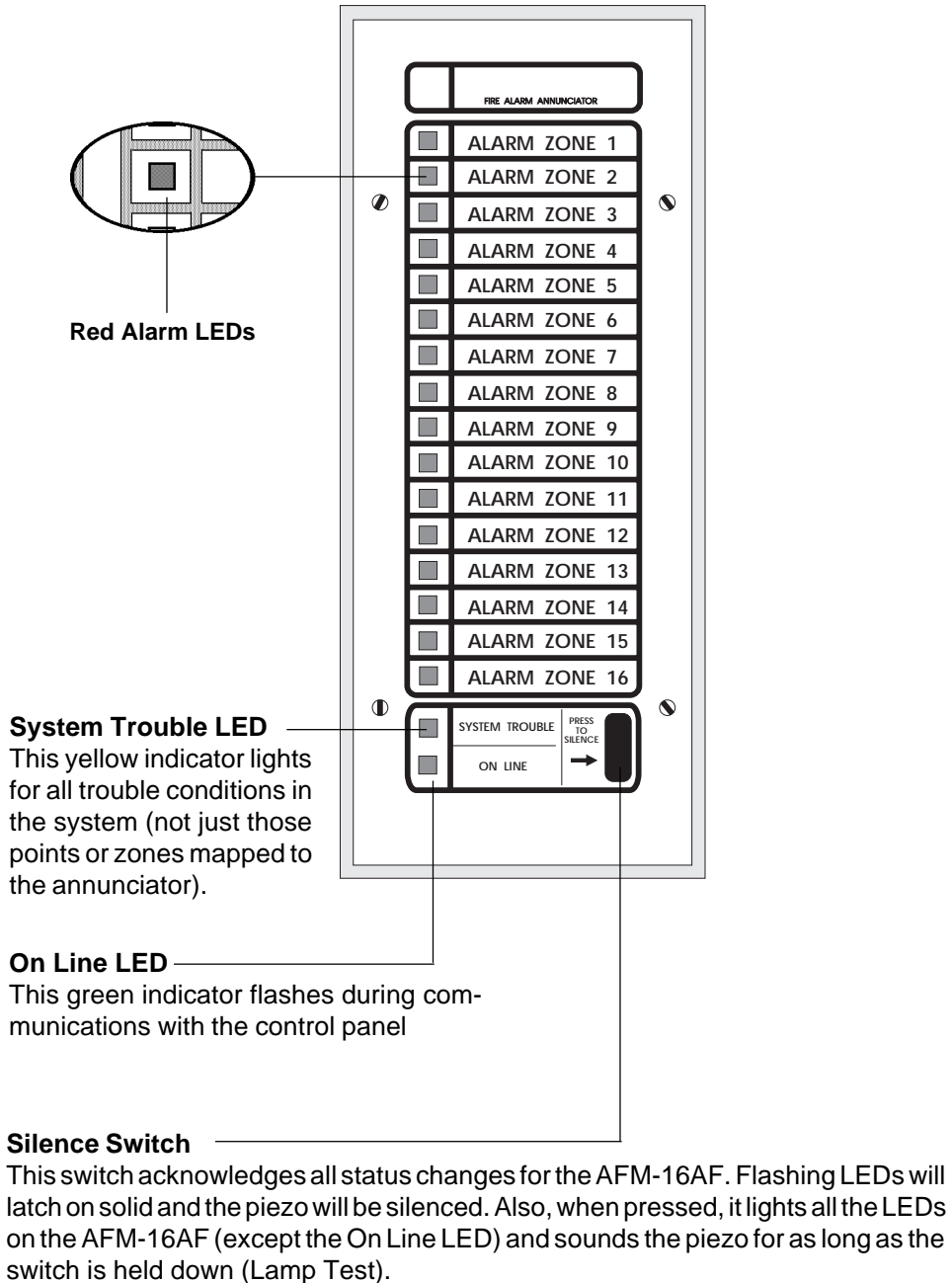

Figure 2-6B:

MPS-24B Main Power Supply

Connect the power run for the AFM to MPS-24B TB2 Terminals 1 (+) and 2 (-). No more than 200 mA current can be drawn from these terminals in standby or in alarm.

Section Three: Operation



**Figure 3-1:
Operation**

Annunciator Operation

Annunciator points "track" or follow those control panel points they are programmed to annunciate; they do not latch. The table below outlines the annunciation of various circuits and functions. Note: Control Switches marked "not used" will still function as local LAMP TEST or local ACKNOWLEDGE switches for their respective points.

**Table 3-1:
Annunciator Point Functions**

	Circuit Type	Red LED
C P U	ANNUNCIATOR POINT # 1	Indicates System Alarm
	ANNUNCIATOR POINT # 2	not used
	ANNUNCIATOR POINT # 3	not used
	ANNUNCIATOR POINT # 4	not used
	ANNUNCIATOR POINT # 5	Indicates that Notification Circuit 1 has been activated
	ANNUNCIATOR POINT # 6	Indicates that Notification Circuit 2 has been activated
	ANNUNCIATOR POINT # 7	Indicates that the Remote Signaling Municipal Tie has been activated
	ANNUNCIATOR POINT # 8	Indicates that the Alarm Relay has been activated
M O D U L E S	IZ-4F, IZ-8F	Indicates alarm status of circuit
	IC-4F, ICE-4F	Indicates Activation
	CR-4F, CRE-4F	Indicates Activation
	TC-2F, TC-4F	Indicates Activation

Notes:

- 1) If Jumper JP1 has not been cut, the eight CPU functions will be not be active on the first eight points of the annunciator.
- 2) These Status LEDs are active only when the CPU has been programmed for "Output Status."

NOTES

**FIRE ALARM
ANNUNCIATOR**

- ALARM ZONE 1**
- ALARM ZONE 2**
- ALARM ZONE 3**
- ALARM ZONE 4**
- ALARM ZONE 5**
- ALARM ZONE 6**
- ALARM ZONE 7**
- ALARM ZONE 8**
- ALARM ZONE 9**
- ALARM ZONE 10**
- ALARM ZONE 11**
- ALARM ZONE 12**
- ALARM ZONE 13**
- ALARM ZONE 14**
- ALARM ZONE 15**
- ALARM ZONE 16**

SYSTEM TROUBLE

ON LINE

PRESS
TO
SILENCE
→

**FIRE ALARM
ANNUNCIATOR**

SYSTEM ALARM

- IND CKT 1**
- IND CKT 2**
- MUNICIPAL TIE**
- ALARM RELAY**
- ALARM ZONE 1**
- ALARM ZONE 2**
- ALARM ZONE 3**
- ALARM ZONE 4**
- ALARM ZONE 5**
- ALARM ZONE 6**
- ALARM ZONE 7**
- ALARM ZONE 8**

SYSTEM TROUBLE

ON LINE

PRESS
TO
SILENCE
→

Cut on dotted line after typing information

**FIRE ALARM
ANNUNCIATOR**

Use these marks to align typewriter when typing two lines per window.

Use these marks to align typewriter when typing one line per window.

SYSTEM TROUBLE
ON LINE

PRESS TO SILENCE
→

Limited Warranty

Fire-Lite® warrants its products to be free from defects in materials and workmanship for eighteen (18) months from the date of manufacture, under normal use and service. Products are date stamped at time of manufacture. The sole and exclusive obligation of **Fire-Lite**® is to repair or replace, at its option, free of charge for parts and labor, any part which is defective in materials or workmanship under normal use and service. For products not under **Fire-Lite**® manufacturing date-stamp control, the warranty is eighteen (18) months from date of original purchase by **Fire-Lite**®'s distributor unless the installation instructions or catalog sets forth a shorter period, in which case the shorter period shall apply. This warranty is void if the product is altered, repaired or serviced by anyone other than **Fire-Lite**® or its authorized distributors or if there is a failure to maintain the products and systems in which they operate in a proper and workable manner. In case of defect, secure a Return Material Authorization form from our customer service department. Return product, transportation prepaid, to **Fire-Lite**®, 12 Clintonville Road, Northford, Connecticut 06472-1653.

This writing constitutes the only warranty made by **Fire-Lite**® with respect to its products. **Fire-Lite**® does not represent that its products will prevent any loss by fire or otherwise, or that its products will in all cases provide the protection for which they are installed or intended. Buyer acknowledges that **Fire-Lite**® is not an insurer and assumes no risk for loss or damages or the cost of any inconvenience, transportation, damage, misuse, abuse, accident or similar incident.

Fire-Lite® GIVES NO WARRANTY, EXPRESSED OR IMPLIED, OF MERCHANTABILITY, FITNESS FOR ANY PARTICULAR PURPOSE, OR OTHERWISE WHICH EXTEND BEYOND THE DESCRIPTION ON THE FACE HEREOF. UNDER NO CIRCUMSTANCES SHALL **Fire-Lite**® BE LIABLE FOR ANY LOSS OF OR DAMAGE TO PROPERTY, DIRECT, INCIDENTAL OR CONSEQUENTIAL, ARISING OUT OF THE USE OF, OR INABILITY TO USE **Fire-Lite**® PRODUCTS. FURTHERMORE, **Fire-Lite**® SHALL NOT BE LIABLE FOR ANY PERSONAL INJURY OR DEATH WHICH MAY ARISE IN THE COURSE OF, OR AS A RESULT OF, PERSONAL, COMMERCIAL OR INDUSTRIAL USE OF ITS PRODUCTS.

This warranty replaces all previous warranties and is the only warranty made by **Fire-Lite**®. No increase or alteration, written or verbal, of the obligation of this warranty is authorized.

"**Fire-Lite**" is a registered trademark.



Fire-Lite® ALARMS
INCORPORATED

12 Clintonville Road,
Northford, CT 06472
Phone: (203) 484-7161
FAX: (203) 484-7118